

Clevertest and Clevertest Plus

Refer to the supplementary operation guide supplied with the Product.

After Power ON, the Status LED on a Clevertest Plus enabled fitting will display a rapid Green or Red flashing for a period up to 2 minutes.

Maintained fittings (CBULKM-xx) cannot be scanned with a camera using the Clevertest Plus App as the maintained light source interferes with the camera scanning function. To register the fitting manually enter the serial number from the QR code and visually read the test result and enter manually into Clevertest Plus App.

Zoneworks, HIVE and DATA Monitored Options

Fittings with part numbers -ZW, -HVG, -DATA are fitted with Zoneworks communications modules (nodes). These fittings are monitored using either Powerline Carrier Technology that utilize the power cable to provide data communication, RF transceiver modules operating in the ISM band or a dedicated data cable to/from data routers installed on a dedicated data trunk connected to a central Server (can also be connected via Ethernet/Internet/Fibre). Zoneworks software on the server is used to monitor, coordinate testing and collate test data from each fitting. Zoneworks Fittings can be commissioned by a single push of the test switch or by scanning the supplied barcode. The LED Test Switch indicator provides a multifunction indication of the status of the fitting during testing and normal operation:

Option	State	LED Operation
ZW, HVG, DATA	Commissioned	LED on Solid (Green)
ZW, DATA	Un-commissioned	Batt plugged-in: yellow 1s, green 1s
		Batt unplugged: red 1s, off 1s
HVG	Un-commissioned With network connectivity	Batt plugged-in: yellow 1s, green 1s
		Batt unplugged: red 1s, off 1s
HVG	Un-commissioned Without network connectivity	Batt plugged-in: yellow 250mS, green 250mS, yellow 250mS, green 250mS, green 1s
		Batt unplugged: red 250mS, off 250mS, red 250mS, off 250mS, off 1s
ZW, DATA	Emergency Light Test In Progress	LED flashes at yellow 5s , Off 1s
HVG	Emergency Light Test In Progress	LED flashes at yellow 1s , Off 1s

In the case of the DATA version a 2-way “figure 8” cable and terminal block facilitates the connection to the DATA network via a multi-drop bus (daisy chain connection). For further information of installation of a Zoneworks system, please refer to the Zoneworks Users Guide and Commissioning Guide (incl. DATA version)

DALI EM Option

Luminaires with part numbers having -DALI are fitted with DALI modules (nodes) that facilitate connection and integration to 3rd Party Lighting Control Systems. Before installing the -DALI fitting please confirm that the Lighting Control System has the capability to monitor DALI Emergency Luminaires. The -DALI fitting will be addressed and configured into the control system by the Lighting Control System Commissioning Technicians and not Clevertronics

State	LED Operation
Commissioned/ Un-commissioned	LED on Solid (Green)
Emergency Light Test in progress	LED flashes at 1s On (Yellow) & 1s Off
“IDENTIFY COMMAND”	Fitting goes into emergency mode for 10 seconds

A 2-way “figure 8” cable and terminal block facilitates the connection to the DALI network OR a 5/6way “structured wiring system” lead and plug facilitating the power and DALI connection. DALI connections are marked as Da Da.

Note:

This luminaire (with reinforced insulation between control/LED terminal and AC supply) contains non-user replaceable light source and battery - to be replaced (if required, refer installation instructions for battery replacement) by Clevertronics service personnel/agents or a registered electrician.



LED Emergency Bulkite Installation & Maintenance Instruction Leaflet



NOTE: Standard product codes with this symbol  are enabled with Clevertest Plus capability. Please refer to the operation guide supplied with the product for details.



Australia (Head Office)
Website: www.clevertronics.com.au
Email: info@clevertronics.com.au
Phone: +61 3 9559 2700
Fax: +61 3 9559 2799

UK OFFICE
Website: www.clevertronics.co.uk
362 Stockley Close
West Drayton UB7 9BL
Phone: 01895 430 255

Models: CBULKy-xx

Testing:

Manual Test xx = Blank
Zoneworks xx = ZW
Z/W DATA xx = DATA
Zoneworks HIVE xx = HVG
DALI Registered. xx = DALI



Options:

Non-Maintained y=Blank
Maintained y=M

Spare Parts:

8050790 HWSUB: CT10754-D2 LED Strip - 2835 LP/L10
8002964 PCA: CT10142-L9 6C150 CTP DALI HVG ZW 250mA Batt
1550231 BATT:LP 3.2V 6400mAh.200mm lead, No Brkt

Important:

It is illegal for anyone, except for a licensed electrician to install or maintain this product. Before installation, ensure that the electricity supply has been switched off and isolated. Installation must be carried out in accordance with the relevant British Standards.

Caution:

On many building sites, power circuits may be cut off in an uncontrolled and repetitive basis during construction. As a result, any Exit & Emergency Units, on these circuits, will have their batteries discharged or “cycled”. The Li-ion battery in the Exit & Emergency Unit has been selected to give excellent long life performance in a controlled IEC 60598-2-22 testing environment. Excessive battery cycling will reduce through-life performance and may lead to premature battery failure. Battery warranty claims, as a result of such abuse, are specifically EXCLUDED from Clevertronics warranty terms.

Installation:

This CBULK Surface Mount Emergency Luminaire can be installed on solid or T-BAR ceilings/surfaces or used to replace an existing unit.

- Locate the installation position.
- Remove the diffuser by levering the 4 clips holding the diffuser (see Below image on how to do this).
- Remove Geartray by undoing the 2 screws holding it in place (using a suitable screwdriver)
- Pre-drill mounting holes (Image showing it below).
- Mount base plate and use suitable fixings to secure the base plate into the pilot holes (including consideration of maintaining the IP rating)
- Bring in supply cables via the rear entry hole or via the ends of the base you will need to drill a suitable hole where cable entry is required).
- Terminate the supply cables to the unswitched Live, Neutral & Earth Loop terminals (in the case of the - DALI or - DATA fittings terminate the DALI or DATA cable to the terminals marked Da Da or DATA).
- Ensure the Battery is connected.
- Push the gear tray back into position and secure in place using the two screws.
- Install the diffuser by pushing it down and squeezing the clips together. Verify that all 4 clips are properly engaged this is ensure the IP seal is (image below)

If the CTP capabilities are activated, please affix the CTP status label to a visible surface and Four Segment Marking on the product will include an "F" in third segment block.

Dimensions:

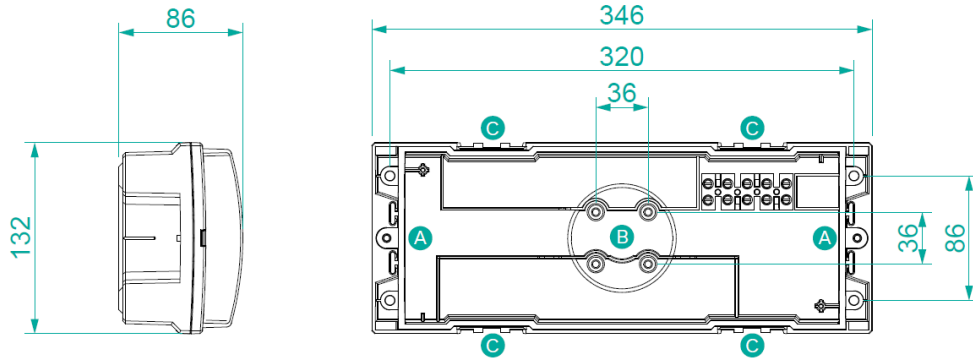

- A END CABLE ENTRY
- B CENTRE CABLE ENTRY
- C COVER CLIP

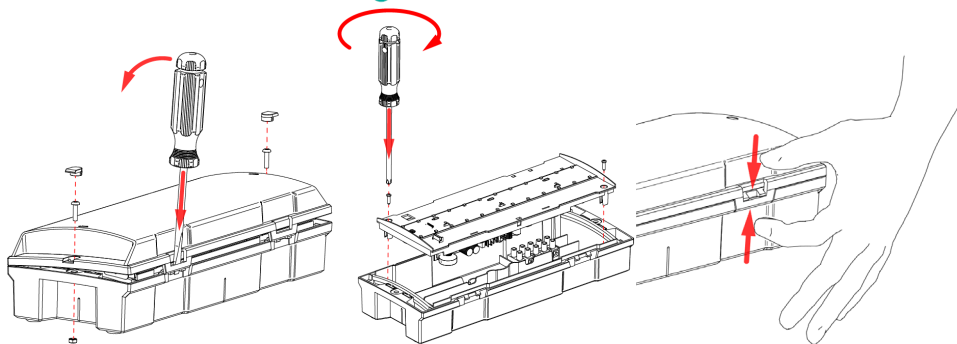

Non-Maintained/Maintained Mode selection

To Change the mode of operation from Non-Maintained to maintained place the jumper across the J4. Image to the right.

NOTE: If you change the product from Non-Maintained to Maintained update the Four Segment Marking on the product to include an "1" in Second segment block.

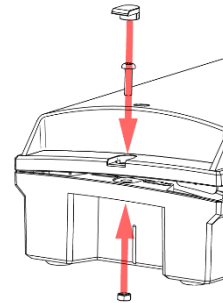
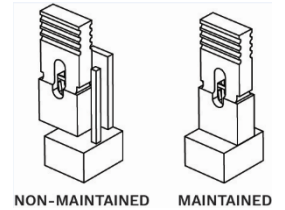

Securing the Diffuser

To secure the diffuser you can add the provided screw and nut. To do this add the nut into the slot provided in the base then use the screw to fix in place.

Battery Replacement:

1. Prior to any work, isolate the power to the luminaire that requires battery replacement
2. Open the fitting by removing the diffuser, see images in installation instruction.
3. Remove the Geartray. Support gear tray while removing the screws
4. Remove the Battery Connector from the Emergency PCA.
5. Remove the battery from the gear tray by removing mounting screws.
6. Replace battery, re-install screws and connect to Emergency Driver.
7. Refit Gear Tray, and diffuser.

Testing Procedure:

When the unit is connected to the un-switched live, it must be allowed to charge the battery for at least 24 hours. Conduct the following tests:

- The emergency lamp must illuminate for at least 180 min after disconnection from the mains. If the unit fails to illuminate for the requisite time, remedial action must be taken to repair the situation and once completed, the unit must pass a subsequent test.
- Press and hold Test Button or switch Off Mains Supply, check that the emergency lamp is On.

Release the Test Button or Switch On Mains Supply, check that the emergency lamp is Off (Non-maintained operation).

Trouble Shooting:

Below are a list of common problems and their possible causes.

Fault: The Green LED Test Switch indicator is not illuminated.

Check: A.C. is connected and is turned on.
Battery is connected
Test Switch for damage.

Fault: Lamp does not illuminate in emergency mode.

Check: A.C. is connected.
Lamp is correctly inserted.
Battery is connected

Fault: Lamp illuminates in emergency mode, but only stays on for a short period.

Check: Battery has been allowed to charge for at least 24 hours.
Battery for damage.

Warranty:

For Product Warranty information and Terms and Conditions of Sales please refer to our website

<https://clevertronics.co.uk/product-warranty-statement/>